

# Thermo Scientific Orbitrap Fusion Tribrid Mass Spectrometer

Unmatched analytical performance,  
revolutionary MS architecture

The Thermo Scientific™ Orbitrap Fusion™ mass spectrometer combines the best of quadrupole, Orbitrap, and linear ion trap mass analysis in a revolutionary Thermo Scientific™ Tribrid™ architecture that delivers unprecedented depth of analysis. It enables life scientists working with even the most challenging samples—samples of low abundance, high complexity, or difficult-to-analyze chemical structure—to identify more compounds faster, quantify them more accurately, and elucidate molecular composition more thoroughly.



- Tribrid architecture combines quadrupole, linear ion trap, and Orbitrap mass analyzers
- Multiple fragmentation techniques—CID, HCD, and optional ETD and EThCD—are available at any stage of MS<sup>n</sup>, with subsequent mass analysis in either the ion trap or Orbitrap mass analyzer
- Parallelization of MS and MS<sup>n</sup> acquisition to maximize the amount of high-quality data acquired
- Next-generation ion sources and ion optics increase system ease of operation and robustness
- Innovative instrument control software makes setup easier, methods more powerful, and operation more intuitive

The Orbitrap Fusion Tribrid MS can perform a wide variety of analyses, from in-depth discovery experiments to characterization of complex PTMs to comprehensive qual/quant workflows. The availability of multiple fragmentation techniques—CID, HCD, ETD, and EThCD—at any stage of MS<sup>n</sup>, with fragment ion detection in either the ion trap or Orbitrap mass analyzer, offers a new level of versatility and performance for the most challenging applications. Users can perform complex MS<sup>n</sup> experiments such as HCD

followed by ETD or EThCD for glycopeptide characterization or HCD followed by CID for small-molecule structural analysis.

The ultrahigh resolution of the Orbitrap mass analyzer increases certainty of analytical results, enabling molecular-weight determination for intact proteins and confident resolution of isobaric species. The unsurpassed scan rate and resolution of the system are especially useful when dealing with complex and low-abundance samples in proteomics, metabolomics, glycomics, lipidomics, and similar applications.

The intuitive user interface of the tune editor and method editor makes instrument calibration and method development easier. The method editor also contains a comprehensive library of application-specific templates for commonly performed analyses.

**Thermo**  
SCIENTIFIC

The optional Thermo Scientific™ EASY-ETD™ ion source uses Townsend discharge ionization to generate a highly stable reagent ion flux. The source is very compact, fitting inside the mass spectrometer. Intelligent, automated precursor ion sorting routines, reagent filtering using the quadrupole mass filter, and charge-state-specific calibration of ETD reaction time maximize the quality of ETD spectra.

## Hardware Specifications

### Ion Source

#### Thermo Scientific™ EASY-Max NG™ Ion Source

- Outstanding performance without adjustments
- Automatic gas and electrical connections on installation
- Enhanced exhaust port efficiently removes solvent vapor, improving uptime and reducing chemical noise

### Ion Optics

#### S-Lens

- Progressively spaced stacked-ring ion guide (S-Lens) captures and efficiently focuses ions in a tight beam
- Large variable spacing between electrodes provides better pumping efficiency and improved ruggedness
- Automatic tuning program optimizes transmission

#### Active Beam Guide

- Reduces noise by preventing neutrals and high-velocity clusters from entering the quadrupole mass filter
- Axial field along the length of the rods improves ion transfer robustness

#### Quadrupole Mass Filter

- MS/MS precursor ion selection with high ion transmission from 50 to 3000  $m/z$
- Precursor ion isolation window widths from 0.4 amu to 1200 amu

#### Ion-Routing Multipole

- Higher-energy collisional dissociation (HCD) cell
- Ion storage with or without fragmentation
- Efficient and stable ion transfer between the ion-routing multipole and the Orbitrap and linear ion trap mass analyzers

#### Orbitrap Mass Analyzer

- Nitrogen-filled C-Trap
- Ultra-high-field Orbitrap mass analyzer with resolving power up to 500,000 FWHM and isotopic fidelity up to 240,000 FWHM at  $m/z$  200

### Dual-Pressure Linear Ion Trap

- High-pressure cell for  $MS^n$  precursor ion isolation from 0.2 amu to 600 amu
- Collision-induced dissociation (CID) and electron-transfer dissociation (ETD)
- Low-pressure cell for improved scan speed, resolving power, and mass accuracy
- Dual-dynode detector with high linear dynamic range for improved quantitation and a large surface area for increased lifespan and robustness

### Vacuum System

- Split-flow turbomolecular pump controlling vacuum in multiple regions
- Precise and accurate low mTorr pressure control in the ion-routing multipole
- Differentially pumped to  $\sim 3 \times 10^{-4}$  Torr in the ion trap chamber
- Differentially pumped to  $< 2 \times 10^{-10}$  Torr in Orbitrap mass analyzer

### Options

#### Thermo Scientific™ Ion Max NG™ Ion Source

- Adjustable heated electrospray ionization (HESI) probe for ultimate sensitivity
- Flow rates from 1  $\mu\text{L}/\text{min}$  up to  $< 2,000 \mu\text{L}/\text{min}$
- APCI probe compatible with liquid flow rates of 50  $\mu\text{L}/\text{min}$  to 2 mL/min without splitting

#### Thermo Scientific™ NanoSpray Flex NG™ Ion Source

- Supports static packed-tip and dynamic nanoelectrospray experiments
- Compatible with liquid flow rates of 50 nL/min to 2  $\mu\text{L}/\text{min}$

#### Thermo Scientific™ EASY-Spray™ Ion Source

- Maximum nanoelectrospray performance with no need for adjustments

#### Thermo Scientific™ EASY-ETD™ Ion Source

- Generates fluoranthene anions for electron transfer dissociation (ETD)
- Townsend discharge ionization is extremely stable and robust
- Compact size, located entirely within the footprint of the instrument
- Active reagent ion filtering using mass-resolving quadrupole

#### Thermo Scientific™ EASY-IC™ Ion Source

- Generates internal calibrant ions for real-time mass calibration on every spectrum
- Provides  $< 1$  ppm RMS mass accuracy

## Performance Characteristics

### Linear Ion Trap Mass Range

Standard –  $m/z$  50–2,000

High Mass –  $m/z$  200–4,000

### Orbitrap Mass Range

Up to  $m/z$  6000 without precursor ion selection

### Resolution

15,000–500,000 (FWHM) at  $m/z$  200

### Scan Rate (under defined conditions)

Orbitrap  $MS^n$  up to 20 Hz

Ion trap  $MS^n$  up to 20 Hz

### Mass Accuracy (under defined conditions)

$< 3$  ppm RMS using external calibration

$< 1$  ppm RMS using internal calibration

### MS/MS Electrospray Ionization (ESI) Ion Trap Sensitivity

2  $\mu\text{L}$  of a 50 fg/ $\mu\text{L}$  solution of reserpine (100 fg total) injected at a flow of 500  $\mu\text{L}/\text{min}$  will produce a minimum signal-to-noise ratio of 100:1 for the transition of the isolated protonated molecular ions at  $m/z$  609 to the largest two product ions,  $m/z$  397 and  $m/z$  448, when the mass spectrometer is operated at unit resolution in the full-scan MS/MS mode,  $m/z$  165–615. The test requires the HESI probe.

### Dynamic Range

$> 5,000$  within a single scan

### MS Scan Power

$MS^n$ , for  $n = 1$  through 10

### Synchronous Precursor Selection

Up to 20 precursors per  $MS^2$  scan, for  $MS^3$  analysis only

### Multiplexing Using Ion-Routing Multipole

Up to 10 precursors per scan using quadrupole mass filter

### Polarity Switching

One full cycle in 1.1 sec (one full scan in positive mode and one full scan in negative mode at resolution setting of 30,000)

### ETD Option

ETD fragmentation efficiency of  $> 15\%$  (infusion of 1 pmol/ $\mu\text{L}$  angiotensin at 3  $\mu\text{L}/\text{min}$ )

### Analog Inputs

One (1) analog input (0–1 V),

One (1) analog (0–10 V)

Figure 1. Orbitrap Fusion ion path

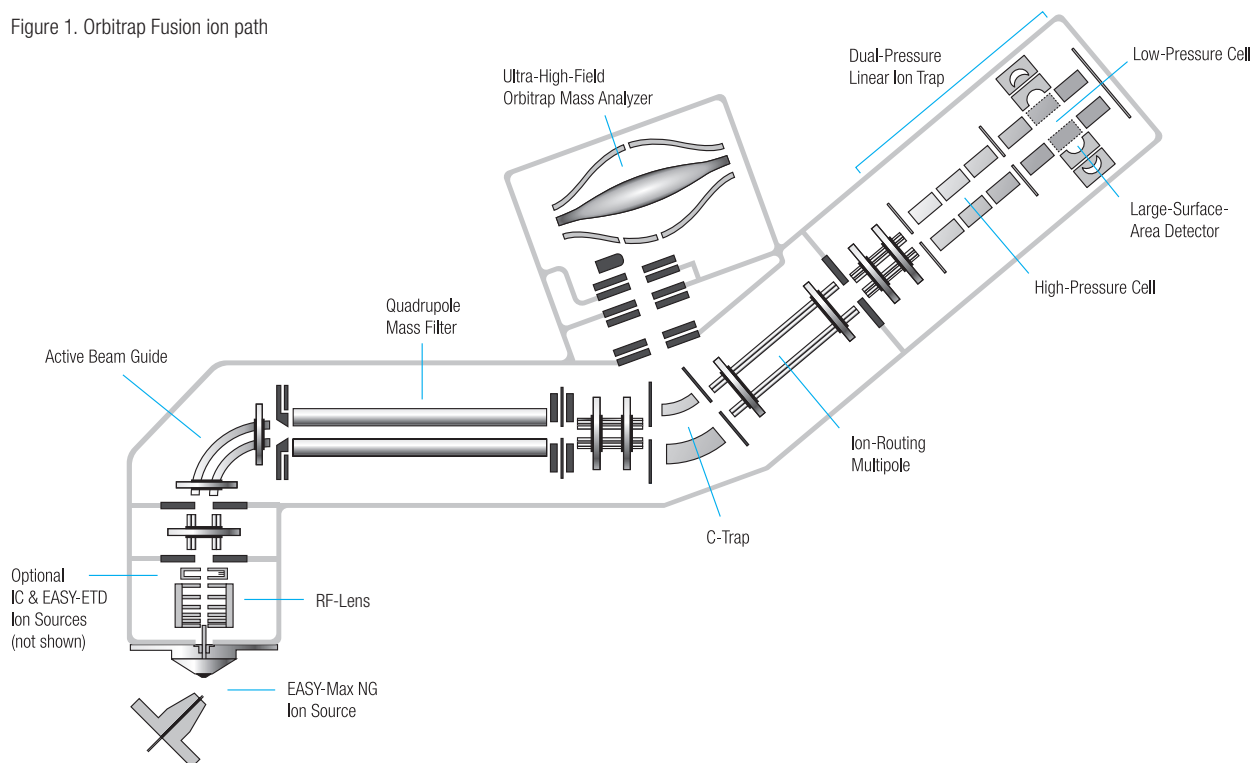

## Software Features

### Data System

- High-performance PC with Intel® microprocessor
- High-resolution LCD color monitor
- Microsoft® Windows® 7 operating system
- Microsoft Office 2010 software
- Thermo Scientific™ Xcalibur™ processing and instrument control software
- Tune editor for system calibration, diagnostics, and manual data acquisition
- Method editor with comprehensive application-specific template library and drag-and-drop user interface to facilitate method development

### Operation Modes

- Top-speed mode maximizes the number of high-quality MS<sup>n</sup> spectra from each cycle by intelligently scheduling MS and data-dependant MS<sup>n</sup> scans based on a user-definable time between adjacent survey scans
- Synchronous MS<sup>3</sup> precursor selection significantly increases the number of peptides accurately quantified in isobaric mass tagging experiments
- Quanfirmation experiment uses synchronous high-resolution, accurate-mass (HR/AM) selected-ion monitoring (SIM) for quantitation and sensitive full-scan MS/MS in the ion trap for precursor identity confirmation
- Parallelization maximizes the amount of high-quality data acquired by synchronizing operation of the quadrupole mass filter, ion-routing multipole, and ion trap and Orbitrap mass analyzers

### Exclusive Technologies

- Dynamic Scan Management allows for intelligent, real-time scheduling, parallelization, and prioritization of the scan events. It also enables selection, sorting, and routing of precursors to different fragmentation modes and analyzers based on user-selected parameters, including precursor *m/z*, intensity, and/or charge.
- Precursor fragmentation can take place in the ion-routing multipole (HCD), in the ion trap (CID, ETD) or both (EThCD) with fragment detection in the linear ion trap or Orbitrap mass analyzers at any stage of MS<sup>n</sup> analysis
- Dynamic exclusion allows acquisition of MS/MS and MS<sup>n</sup> spectra from lower-intensity ion species
- Automatic gain control (AGC) ensures that the ion trap is always filled with the optimum number of ions for any scan type
- Normalized collision energy for both CID and HCD fragmentation techniques ensures reproducible data from instrument to instrument

### Advanced Data-Dependent Experiments

- Dynamic Scan Management facilitates a wide range of data-dependent experiments with real-time selection, prioritization, and routing of precursors to different fragmentation modes and analyzers based on user-selected parameters including precursor *m/z*, intensity, and/or charge
- Fragment ion or neutral-loss-triggered MS<sup>n</sup> experiments including at the same MS<sup>n</sup> level
- Synchronous MS<sup>3</sup> precursor selection significantly increases the number of peptides accurately quantified in isobaric mass tagging experiments

- Data-dependent neutral-loss experiment triggers MS<sup>3</sup> scans on only MS/MS product ions with a predefined neutral loss
- Isolation window offset allows for custom centering of the isolation window when working with broad isotopic distributions
- Quanfirmation experiment uses synchronous HR/AM SIM for quantitation with full-scan MS/MS in the ion trap for precursor identity confirmation

### Optional Application-Specific Software

- Thermo Scientific™ Compound Discoverer™ software – integrated solution for small-molecule structural identification
- Thermo Scientific™ Mass Frontier™ software – predictive fragmentation software for spectral interpretation and classification software to identify unknowns
- Thermo Scientific™ Pinpoint™ software – comprehensive targeted protein quantitation platform
- Thermo Scientific™ ProSightPC™ software – stand-alone software for analyzing top-down intact-protein data, but also middle-down and bottom-up data
- Thermo Scientific™ Protein Deconvolution software – intact-protein analysis platform
- Thermo Scientific™ Proteome Discoverer™ software – flexible, expandable platform for the analysis of qualitative and quantitative proteomics data
- Thermo Scientific™ SIEVE™ software – label-free, semi-quantitative differential analysis of highly complex data sets

## Installation Requirements

### Power

- Instrument – 230 Vac  $\pm$  10% single phase, 15 Ampere, 50/60 Hz, with earth ground
- Data system – 120 or 230 Vac single phase, 50/60 Hz, with earth ground

### Gas

- Ultra-high-purity helium (99.999%) with less than 1 ppm each of water, oxygen, and total hydrocarbons
- High-purity nitrogen (99.5% pure, flow rate 15 L/min) nitrogen gas supply for the ion source
- Ultra-high-purity nitrogen (UHP, 99.999%) with less than one ppm each of water and oxygen for the ion-routing multipole and ETD/IC

### Size

1270  $\times$  767  $\times$  703 mm (w, d, h). The system comes mounted on a 1320  $\times$  788  $\times$  726 mm (w, d, h) table, similar to a standard lab bench

### Weight

318 kg (700 pounds) with table but without data system, vacuum rough pumps, and optional items

### Environment

- System averages 2,800 W (10,000 Btu/hr) output
- Operating environment must be 16–26 °C (59–78 °F) and relative humidity must be 50–80% with no condensation
- Optimum operating temperature is 18–21 °C (65–70 °F)

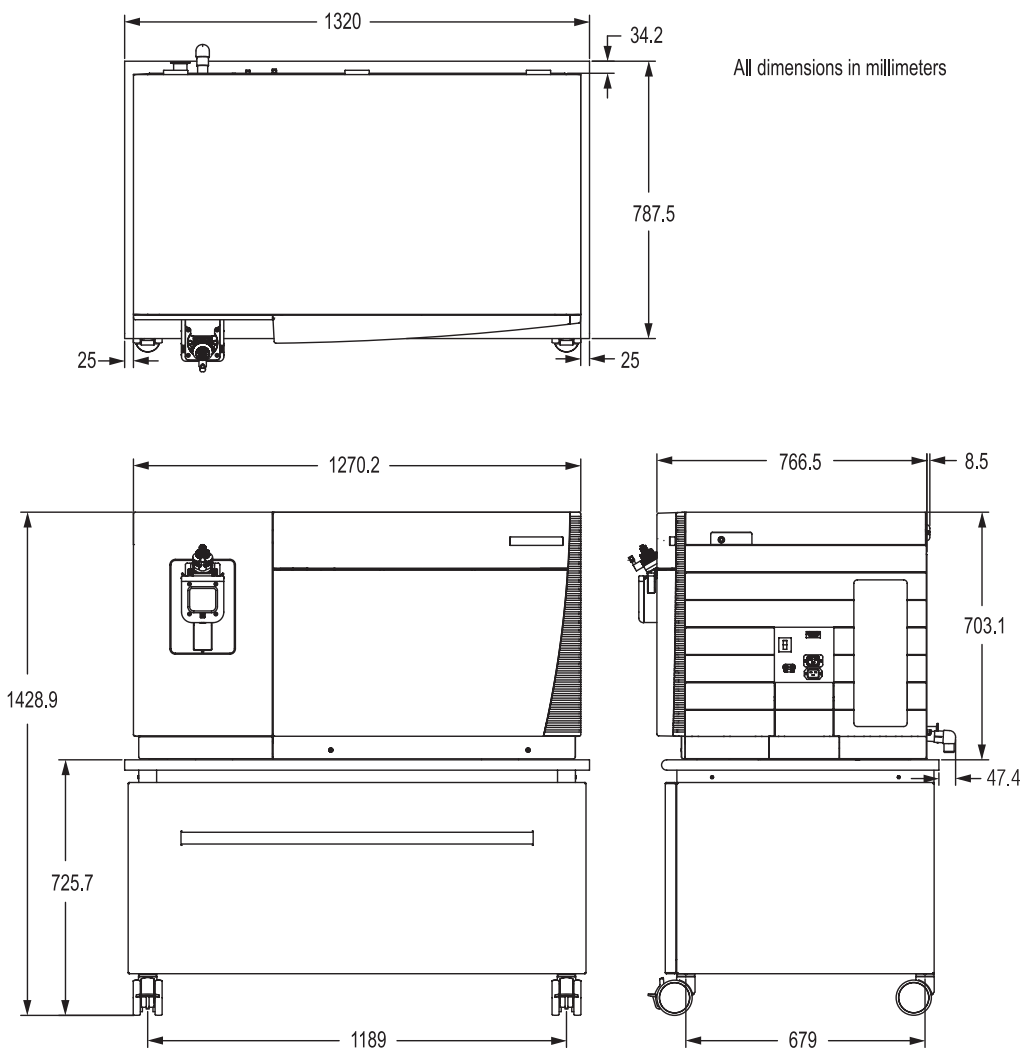

Figure 2. Orbitrap Fusion MS dimensions

**For Research Use Only. Not for use in diagnostic procedures.**

[www.thermoscientific.com](http://www.thermoscientific.com)

©2016 Thermo Fisher Scientific Inc. All rights reserved. ISO is a trademark of the International Standards Organization. Intel is a registered trademark of Intel Corporation. Microsoft and Windows are registered trademarks of Microsoft Corporation. All other trademarks are the property of Thermo Fisher Scientific Inc. and its subsidiaries. Specifications, terms and pricing are subject to change. Not all products are available in all countries. Please consult your local sales representative for details.



Thermo Fisher Scientific,  
San Jose, CA USA is  
ISO 9001:2008 Certified.

<b>Africa</b> +43 1 333 50 34 0	<b>Denmark</b> +45 70 23 62 60	<b>Japan</b> +81 45 453 9100	<b>Russia/CIS</b> +43 1 333 50 34 0
<b>Australia</b> +61 3 9757 4300	<b>Europe-Other</b> +43 1 333 50 34 0	<b>Korea</b> +82 2 3420 8600	<b>Singapore</b> +65 6289 1190
<b>Austria</b> +43 810 282 206	<b>Finland</b> +358 10 3292 200	<b>Latin America</b> +1 561 688 8700	<b>Spain</b> +34 914 845 965
<b>Belgium</b> +32 53 73 42 41	<b>France</b> +33 1 60 92 48 00	<b>Middle East</b> +43 1 333 50 34 0	<b>Sweden</b> +46 8 556 468 00
<b>Canada</b> +1 800 530 8447	<b>Germany</b> +49 6103 408 1014	<b>Netherlands</b> +31 76 579 55 55	<b>Switzerland</b> +41 61 716 77 00
<b>China</b> 800 810 5118 (free call domestic) 400 650 5118	<b>India</b> +91 22 6742 9494	<b>New Zealand</b> +64 9 980 6700	<b>UK</b> +44 1442 233555
	<b>Italy</b> +39 02 950 591	<b>Norway</b> +46 8 556 468 00	<b>USA</b> +1 800 532 4752

**Thermo**  
SCIENTIFIC

A Thermo Fisher Scientific Brand